

Revised 2-18-94

Power Trim Leak Down - 40 Thru 115

NOTICE

This is a revision of Outboard Service Bulletin 93-22. Destroy Bulletin 93-22 and insert Bulletin 93-22A. Changes are underlined>.

Mariner And Mercury

1993 and 1994 40 Thru 115

Serial Numbers

US 0D233717 Thru 0G036976

Belgium 09770362 Thru 09805430

The 1993 and 1994 models listed with power trim date codes 13011 thru 23288 ONLY may experience a very slow up trim rate (one minute or more) with the outboard drifting back down as soon as the UP trim button is released. This failure usually occurs when the unit is new or after three or four weeks of non use. The cause may be a stuck spool inside the sleeve due to an oversize or a hard O-ring on the spool.

NOTE: Slow or overnight type leak downs are not a symptom of a sticking pilot valve. Refer to "Service Tip" later in this bulletin.

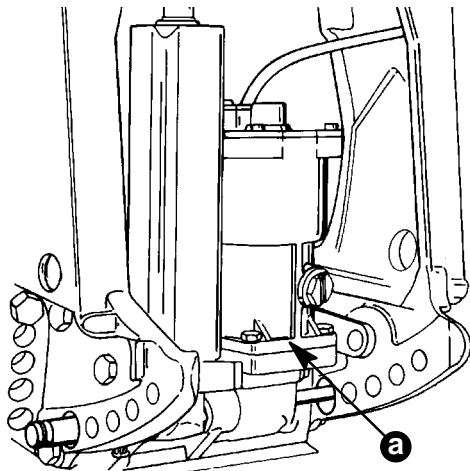
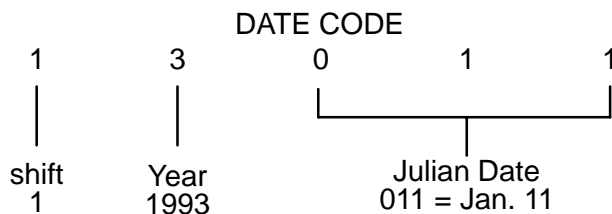

a - Date Code

Figure 1. Date Code Location.

REPAIR:

To correct, remove the tilt cylinder from the manifold and replace the pilot valve assembly as outlined in the outboard service manual. It is NOT necessary to replace the complete power trim to correct the problem.

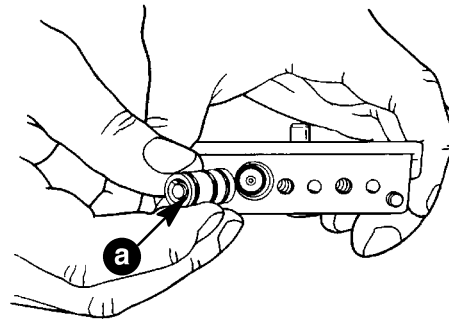

50999

a - Sleeve with Spool Inside.

Figure 2. Side View of Manifold.

The spool is stuck when the pin end of the spool is protruding out past the end of the sleeve.

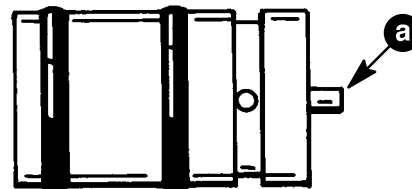

52790

a - Spool Pin.

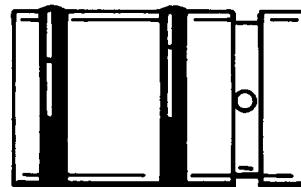
Figure 3. Spool Stuck.

52791

Figure 4. Spool Not Stuck.

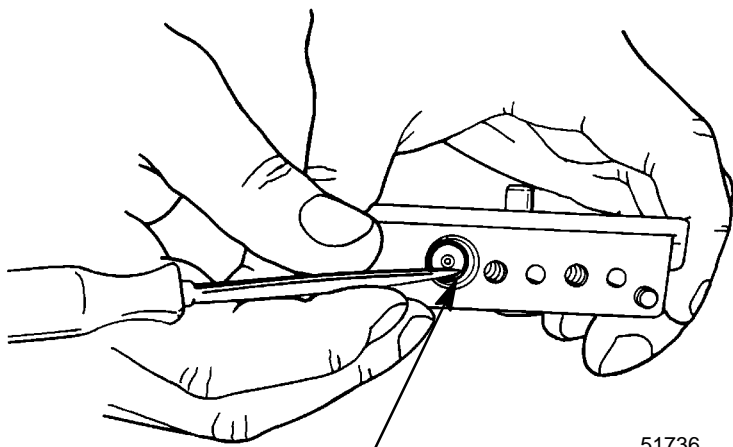

51736

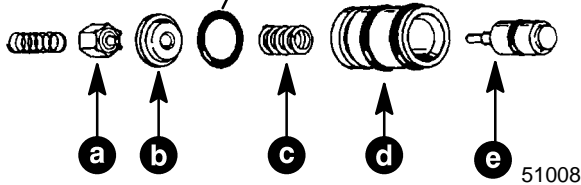

51008

- a - Pilot Valve.
- b - Valve seat.
- c - Return Spring.
- d - Sleeve.
- e - Spool.

Figure 5. Pilot Valve and Seat Removal.

A leak path is created between the UP side of the cylinder and the reservoir, when the spool sticks holding the pilot valve open.

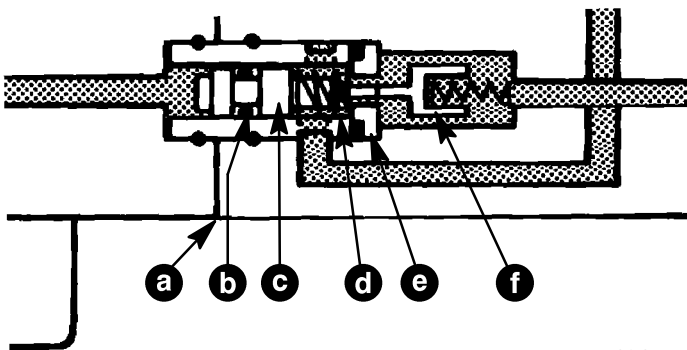

51647

- a - Cylinder/Manifold Mating Surface.
- b - O-Ring in Question.
- c - Spool.
- d - Return Spring.
- e - Valve Seat.
- f - Pilot Valve Held Open (away from valve seat).

Figure 6. Pilot Valve Held Open.

Replacement parts are contained in the screw and seal kits listed.

SCREW AND SEAL KIT

40 Thru 60
811226A-1

75 Thru 115
811678A-4

We have not had any failures on 75 thru 115 models which uses the same sleeve and spool. This is probably due to the stiffer return spring that is used on the actuator spool.

Power trim units with date code 23289 and higher have improved O-rings and improved surface finish on the inside of the sleeve to correct the problem.

INSTALLATION TIPS:

Install the spool into the sleeve from the chamfered end (end opposite the cross hole).

Insert spool into sleeve until spool end is flush with the chamfered end of the sleeve. Inserting the spool too far into the sleeve may allow the spool O-ring to contact the sharp edges of the sleeve cross hole and damage the O-ring.

SERVICE TIP:

To correct a slow leak down, check for debris between the valve seat and valve.

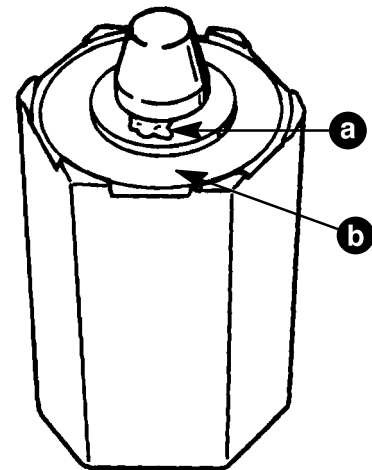

52792

- a - Chip Under Valve Tip.
- b - Rubber Seat.

Figure 7. Pilot Valve End.

WARRANTY:

Complete a warranty claim listing:

Part number of kit used.

One (1) hour labor.

Labor Rate Code NJC.

Failure code 199 00

US and Canada: Return the pilot valve assembly with the claim.

International: Hold the pilot valve assembly for inspection/disposal by a Marine Power International technical representative.