

## Driveshaft Replacement 30/40 and 50 (4-Stroke)

### Models Affected

#### MARINER AND MERCURY

1995 30/40 Long Shaft (20 in.) Only  
Serial Number  
US 0G240473 thru 0G277335  
Belgium 09864779 thru 09871064

1995 50 (4-Stroke)  
Serial Number  
US 0G231242 thru 0G270385

The outboards listed may have driveshafts with defective welds. Endurance testing has discovered a small possibility of voids in the weld that joins the stainless steel upper section to the carbon steel lower section of the driveshaft. Operation of the outboard may result in early driveshaft failure.

#### OWNER NOTIFICATION (US AND CANADA)

A combination letter/claim (US) or a letter (Canada) will be sent to every registered owner of an affected outboard. The letter will advise the owner to return their outboard to their selling dealer or any authorized dealer for inspection and possible replacement of the driveshaft. A copy of the letter/claim is included with this Service Bulletin.

#### CORRECTION OF REGISTERED OUTBOARDS

1. Remove gear housing and the driveshaft as outlined in the Outboard Service Manual.
2. Check the date code on the driveshaft per Figure 1.
3. Driveshaft **MUST BE** replaced if the date code is 5190 thru 5233.
4. Order Parts Kit p/n 809796A1 and driveshaft (if required) per this bulletin for reassembly.
5. Reassemble and install the gear housing as outlined in the Outboard Service Manual.
6. Fill the gear housing with Quicksilver gear lube, install the propeller, and check for proper operation of the outboard.

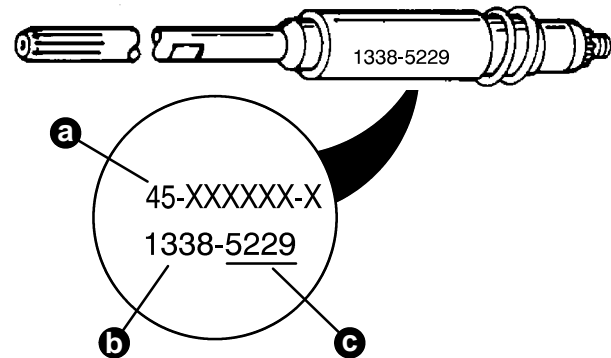

- a - Driveshaft Part Number
- b - Manufacturing Number
- c - Date Code

**Figure 1. Driveshaft Date Code**

#### REWORK/PART IDENTIFICATION

Outboards within the serial number range listed that have been reworked at the factory are identified by:

A red or black letter "D" hand applied with a marker on the outboard serial number label of the shipping carton.

A yellow dot or marking painted on the powerhead (Figures 2 or 3).

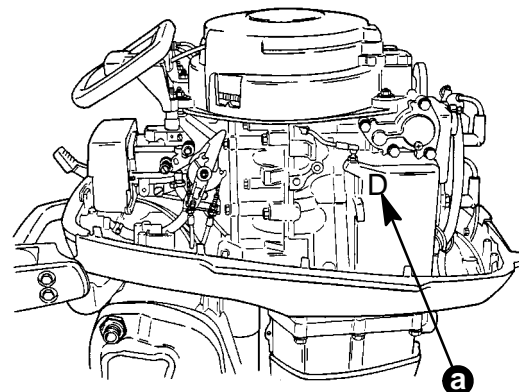

- a - Yellow Paint Dot

**Figure 2. 30/40 Rework Marking**

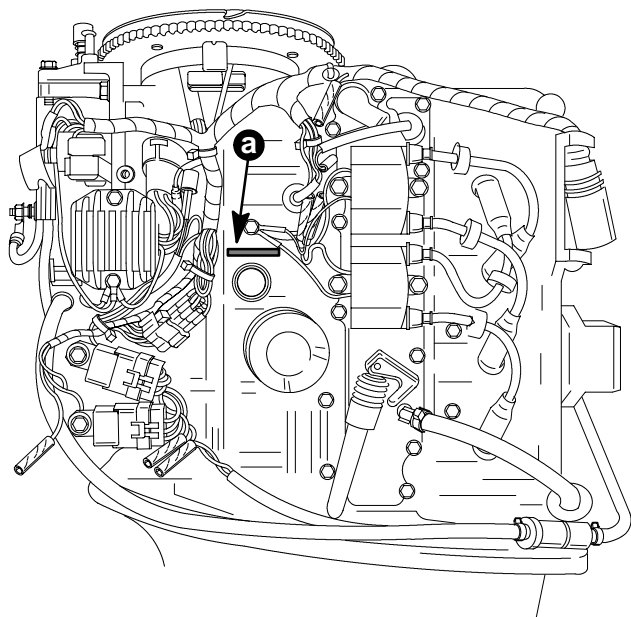

a - Yellow Paint Marking

**Figure 3. 50 4-Stroke Rework Marking**

**DEALER OUTBOARD INVENTORY**

1. Check outboard and/or shipping carton within the affected serial number range for factory rework identification markings.
2. Outboards within this serial number range that have not been reworked at the factory, must have the gear housing replaced. As an alternative, the driveshaft must be inspected and replaced if the date code is 5190 thru 5233 (Figure 1).
3. For assistance:

**USA:** Use Quick-fax (800-842-4550) or call Mercury/Mariner Outboard Service at (414-929-5884) for a pre-authorized warranty to replace the gear housing assembly.

**CANADA:** Use Quick-fax (800-663-8334) or call Mercury Marine Service/Warranty (905-270-4481).

**INTERNATIONAL:** Call your area office.

**SPECIAL TOOLS/SERVICE MANUAL REQUIRED**

**30/40**

PART NO.	DESCRIPTION
91-825196	Driveshaft Holding Tool
90-826148	30/40 Service Manual

**50 (4-STROKE)**

PART NO.	DESCRIPTION
91-83180M	Driveshaft Holding Tool
90-828631	50 (4-Stroke) Service Manual

**PARTS KIT 809796A1 COMPONENTS**

QTY.	PART NUMBER/DESCRIPTION
(1)	11-55910 Pinion Nut
(1)	25-815460 "O" Ring - Bearing Carrier
(1)	25-821308 "O" Ring - Water Pump Base
(1)	27-822217 Base Gasket - Water Pump
(1)	27-822189 Cover Gasket - Water Pump
(2)	12-86645--1 Washer - Impeller
(2)	12-19183 Sealing Washer

**WARRANTY**

Complete a warranty claim listing:

Outboard serial number

**For Driveshaft Inspection (Only)**

- Qty 1 - p/n 809796A1 parts kit
- Qty 1 - p/n 92-19007--1 bottle (32 fl. oz.) Quicksilver Gear Lube
- 1.5 hours labor
- Flat Rate Code OG11
- Failure Code 205 00

**For Driveshaft Replacement**

- Qty 1 - p/n 45-\_\_\_\_\_ Driveshaft
- Qty 1 - p/n 809796A1 parts kit
- Qty 1 - p/n 92-19007--1 bottle (32 fl. oz.) Quicksilver Gear Lube
- 1.5 hours labor
- Flat Rate Code OG11
- Failure Code 205 00

**For Gear Housing Replacement**

- Qty 1 - p/n 1682-\_\_\_\_\_ Gear Housing Assembly
- 0.7 hour labor
- Flat Rate Code OG12
- Failure Code 205 00

**USA:** Return gear housing assembly with a copy of the warranty claim.

Return driveshaft assembly with a copy of the warranty claim if a driveshaft is replaced.

**CANADA:** Return gear housing assembly with a copy of the warranty claim to Mercury Marine Mississauga.

Return driveshaft with a copy of the warranty claim if a driveshaft is replaced.

**INTERNATIONAL:** Tag and hold gear housing assembly and driveshaft for inspection / disposal by a Marine Power International Technical Representative.

## **DRIVESHAFT/GEAR HOUSING ASSEMBLY PART NUMBERS**

### **30/40 Mariner/Mercury**

<b>PART NUMBER</b>	<b>DESCRIPTION</b>
45-822159A1	Driveshaft (L) 20 in.
1682-821306A6	Gear Housing (Long-Black)
1682-821306A7	Gear Housing (Long-Gray)

### **50 (4-Stroke) Mariner/Mercury**

<b>PART NUMBER</b>	<b>DESCRIPTION</b>
45-826194A1	Driveshaft (L) 20 in.
45-826195A1	Driveshaft (LL) 22.5 in.
1682-821306A17	Gear Housing (Long-Black)
1682-821306A18	Gear Housing (Long-Gray)



A BRUNSWICK COMPANY

W6250 W. PIONEER ROAD  
P.O. BOX 1939  
FOND DU LAC, WI 54936-1939 U.S.A.  
PHONE (414) 929-5000 H FAX (414) 929-5060

Dear Owner:

Our records indicate you own a Mercury/Mariner outboard that may contain a defective driveshaft. We discovered this possibility through our rigorous endurance testing procedure. If the driveshaft fails, your motor will not be able to propel a boat; its propeller will not revolve at all.

**WHAT YOU SHOULD DO**

Contact your authorized dealer, preferably the one who sold you your motor, and make an appointment to have them perform the work prescribed by service bulletin 95-7. Then, deliver your boat and this letter to the dealer at the appointed time. The other side of this letter is a claim your dealer needs to send to us to get paid for this service.

**WHAT WE WILL DO**

We will reimburse the authorized dealer for providing the necessary service. You will not be charged for this procedure.

We regret, and sincerely apologize for, any inconvenience this action causes for you. However, we have taken this action to insure your boating enjoyment and continued satisfaction with our product.

Sincerely,  
Mercury Marine

A handwritten signature in black ink that reads "Bob Kachelek".

Bob Kachelek  
Director, Outboard Service

**Warranty  
Claim**