

Official Notification Federal Boat Safety Act Reverse Lock Link Rod Replacement - 15 (4-Stroke)

Models Affected

MERCURY/MARINER

1998 15 (4-Stroke)

USA S/N 0G590000 thru 0G736819

Outboards listed require replacement of the reverse lock link rod prior to operation. Affected units were assembled with reverse lock link rods which can come in contact with the lower cowl pan and deflect (bend) out of adjustment. This misadjustment can engage the reverse lock hooks in forward gear and not allow the outboard to be tilted up. Should the lower unit strike a submerged object while the boat is in forward gear, this condition could cause damage to the reverse lock mechanism and/or at slower boat speeds result in a sudden unexpected boat stoppage.

Owner Notification

A letter will be sent to every registered owner of an affected outboard. The letter will advise the owner to return their outboard to their selling dealer or any authorized dealer for replacement of the reverse lock link rod. A copy of the letter is included with this Service Bulletin. As the letter indicates, this recall campaign is being run in conjunction with Service Bulletin 98-14 "Upper Motor Mount Replacement - 9.9/15 (4-Stroke)".

Repair Identification

Outboards within the serial number range listed that have been reworked at the factory are identified by:

- A black dot sticker applied on the outboard serial number label of the shipping carton.
- A black dot sticker applied on the fuel pump cover.
- Use MIDAS - Product History, to determine if this fix campaign 1998-013 is "OPEN" or has been "COMPLETED".

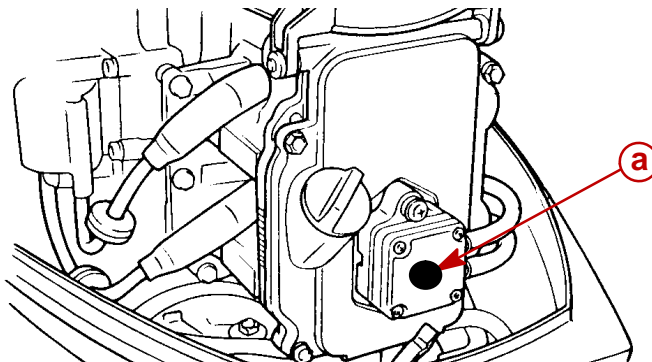

a - Black Dot Sticker

Dealer Outboard Inventory

Affected outboards in dealer inventory **MUST BE** re-worked prior to customer delivery.

Service Parts Stock

Dealer parts inventory was not affected.

Correction

Replace the existing reverse link rod assembly, as outlined in the installation instructions supplied with Reverse Lock Link Rod Kit (p/n 858338A3).

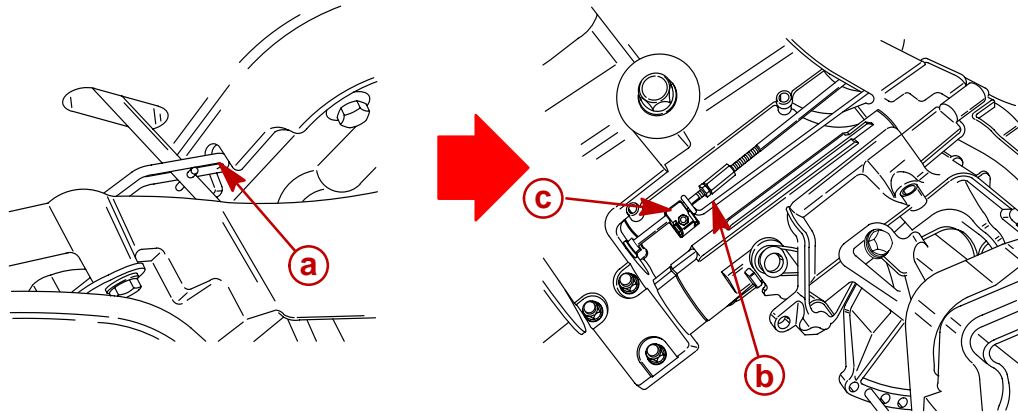

57141

- a** - Upper Reverse Lock Link Rod - Early design (actuated by a cross pin) making contact with lower cowl.
- b** - Reverse Lock Link Rod Kit (p/n 858338A3) - Current design, actuated by reverse hook guide.
- c** - Reverse Hook Guide

Parts Required

Qty. 1 p/n 858338A3 Reverse Lock Link Rod

Warranty

Complete a warranty claim listing:

- Outboard serial number(s)
- Qty 1 p/n 858338A3 Reverse Lock Link Rod Kit
- One half (0.5) hour labor
- Warranty Flat Rate Code: CD28
- Failure Code: 116-40

USA and CANADA: Complete/process claim via Midas or return a warranty claim form. Discard reverse lock link rod pieces from disassembly.

INTERNATIONAL: Follow instructions issued by Marine Power International office or by your distributor.



W6250 PIONEER ROAD
P.O. BOX 1939
FOND DU LAC, WI 54936-1939 U.S.A.

PHONE (920) 929-5000 ■ FAX (920) 929-5060

Dear Customer:

Our records indicate that you are the owner of a 15 horsepower 4-stroke out-board engine included in a recall being conducted in accordance with the requirements of the Federal Boat Safety Act.

Your engine has two separate potential problems that need to be repaired.

1. The reverse lock mechanism in your engine could malfunction and engage while shifted into forward gear. This would lock your engine down and prevent it from tilting up. Should you strike a submerged object while underway, the reverse lock could be damaged, or, at slower speeds, your boat could suddenly and unexpectedly come to a complete halt.
2. The motor mounts could separate and allow the engine to fall off of the boat.

DO NOT OPERATE YOUR ENGINE UNTIL THESE REPAIRS ARE DONE

WHAT YOU SHOULD DO . . .

Contact your authorized dealer, preferably the one who sold you the engine, and make arrangements to deliver your boat to the dealer to have the necessary repairs performed. The reverse side of this letter is a pre-printed recall form covering the service.

WHAT WE AND YOUR DEALER WILL DO . . .

The dealer will perform the repairs at no charge to you. We will reimburse the dealer upon receipt of the claim.

Please make arrangements to have this work done as soon as possible. We apologize for inconveniencing you, but we are taking this action in the interest of your safety and satisfaction.

Sincerely,

Bob Kachelek
U.S. Service

Ralph Lawson
Canadian Service

