

Circulate to:  Sales Manager  Accounting  Service Manager  Technician  Parts Manager

## Electronic Steering Helm Motor Fault Diagnostics

### Scope

Worldwide

### Models Affected

Description	Serial Range
Zeus	All Models
Axius	
Joystick Piloting for Outboards	

### Situation

The following electronic steering helm motor faults commonly show up in the Freeze Frame of one of the CCMs of a boat equipped with a Mercury joystick piloting system.

- **Pseudo\_Abs\_Range\_Low**
- **WheelPosMyRel\_Diff**
- **WheelPosPeerRel\_Diff**
- **WheelInRateMode**

These faults are commonly used as direction to replace electronic steering helm motors. This direction can result in replacement of components that are not defective. The replacement of nondefective parts is not covered by Mercury Marine warranty.

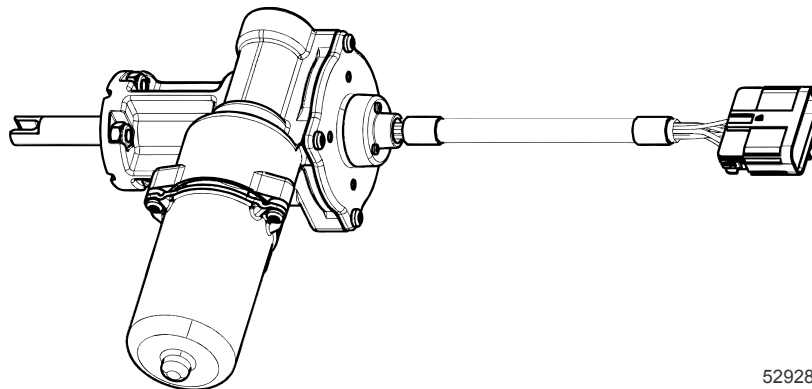

52928

### Correction

For detailed corrective actions for these faults and other related electronic steering helm motor faults refer to the diagnostic table on the following pages of this service bulletin.

THE INFORMATION IN THIS DOCUMENT IS CONFIDENTIAL AND PROTECTED BY COPYRIGHT AND IS THE PROPERTY OF MERCURY MARINE.

This document is provided for the sole and exclusive use of the original recipient as prescribed by Mercury Marine and may not be distributed or copied, digitally or otherwise, without the prior written consent of Mercury Marine.

Following are brief explanations of scenarios where these faults can be experienced, but do not indicate a faulty electronic steering helm motor.

1. **Pseudo\_Abs\_Range\_Low** is commonly found in the freeze frame of only the port CCM. The cause for this can be that the port engine or key switch was turned on with the starboard key switch turned off.
2. **WheelPosMyRel\_Diff** or **WheelPosPeerRel\_Diff** is found in the freeze frame of either CCM. This may have simply been due to either of the keys on with the other keys left in the off position.
3. **WheelInRateMode** can be found in either CCM when the steering wheel has not been configured with CDS G3. When this fault is only found as active in the port CCM or stored only in the port CCM, it can indicate that the boat has been operated without the starboard key on.

**NOTE:** Voltage supply levels, poor connection integrity on grounds or power leads, as well as any recent service activity where components were disconnected or calibrations updated can lead to the scenarios described above as well.

This information will be added to service and diagnostic manuals as they are updated in future releases. Please place the following pages of information with your service manuals for the applicable products.

**Key operating instructions:**

- Single engine operation should be a temporary operating mode and both keys should be in the on position.
- Always turn on the starboard key first.
- Always turn off the starboard key last.

**NOTE:** Operating in single engine mode with both keys on for an extended time may result in the battery depleting on the engine that is not running.

Fault	CCM	Description	Diagnostic and Corrective Actions
<p><b>Pseudo_Abs_Range_Low</b> <b>Pseudo_Abs_Range_High</b></p>	<p>Port</p>	<p>Pseudo in the name indicates that there is no direct wire between the port CCM and the absolute position sensor. These faults indicate that the range of the pseudo steering signal is too far outside of adapted value range.</p>	<ul style="list-style-type: none"> <li>• If the fault is active: Make sure that both keys are in the on position. Verify that the accompanying fault AbsPos_Range_Low (or High) is active in the starboard CCM. If both faults remain active, diagnose the absolute position sensor circuit and sensor as directed in the service manual.</li> <li>• If the fault is in freeze frame: Verify that the accompanying fault AbsPos_Range_Low is in the freeze frame of the starboard CCM.</li> <li>• For Pseudo_Abs_Range_Low: If the accompanying fault AbsPos_Range_Low is not found in the starboard CCM as active or in the freeze frame, refer to the key operating instructions in the service bulletin. Do not replace the helm motor.</li> </ul>
<p><b>AbsPos_Range_Low</b> <b>AbsPos_Range_High</b></p>	<p>Starboard</p>	<p>The absolute position sensor, which is connected only to the starboard CCM, is too far outside of adapted value range.</p>	<ul style="list-style-type: none"> <li>• If the fault is active: Diagnose the absolute position sensor as directed in the service manual.</li> <li>• If the fault is in freeze frame: Attempt to make the fault show up as active by turning the steering wheel slowly while monitoring the View Faults screen in CDS G3. If the fault status changes to active, diagnose the fault as directed in the service manual. If the fault status cannot be changed to active, perform a wiggle test of connectors and wires at CCM and helm motor with keys on to attempt to locate a bad pin or connector. Correct as appropriate. If the fault cannot be duplicated as active, clear the freeze frame and contact Mercury product support.</li> </ul>

THE INFORMATION IN THIS DOCUMENT IS CONFIDENTIAL AND PROTECTED BY COPYRIGHT AND IS THE PROPERTY OF MERCURY MARINE.

This document is provided for the sole and exclusive use of the original recipient as prescribed by Mercury Marine and may not be distributed or copied, digitally or otherwise, without the prior written consent of Mercury Marine.

Fault	CCM	Description	Diagnostic and Corrective Actions
<p><b>WheelPosMyRel_Diff</b> <b>WheelPosPeerRel_Diff</b></p>	<p>Starboard or Port</p>	<p>This fault indicates that the encoder that is identified by the "peer" or "my" indication in the fault name is failing the comparison done by the CCMs for both the absolute position sensor and the encoder.</p>	<ul style="list-style-type: none"> <li>• If the fault is active: Diagnose the encoder that is identified by the CCM that has WheelPosMyRel_Diff as directed in the service manual.</li> <li>• If the fault is in freeze frame: Attempt to make the fault show up as active by turning the steering wheel slowly while monitoring the View Faults screen in CDS G3. If the fault status changes to active, diagnose the fault as directed in the service manual. If the fault status cannot be changed to active, perform a wiggle test of connectors and wires at CCM and helm motor with keys on to attempt to locate a bad pin or connector. Correct as appropriate. If the fault cannot be duplicated as active status, clear the freeze frame and contact Mercury product support.</li> </ul>
<p><b>WheelInRateMode</b></p>	<p>Starboard or Port</p>	<p>This fault indicates that the system does not have the ability to enact self-centering or end stops. Rate mode is the mode the wheel operates in when it is unable to exert control over the wheel position, such as for end stops or to move itself to the straight ahead position. Rate mode can be induced if the absolute position sensor is out of range, or it can be a result of the end stops being exceeded. It will also be active if the wheel configuration has not been completed.</p>	<ul style="list-style-type: none"> <li>• If the fault is active: Enter the wheel configuration screen on CDS G3 helm configuration menu. From this screen you will be able to evaluate if the wheel has not been configured. The field of value <b>Helm requires adapting</b> will be <b>true</b> if the adaptation has not been completed. Follow the directions to complete adaptation.</li> <li>• Check for Wheel_EndStopExceeded fault. If this fault is active, then the end stop has been overcome by the operator. Cycle both key switches off, pull control handles to reverse wide-open throttle positions. Wait 10 seconds. Key back on and check for end stops and faults.</li> <li>• If the fault is in freeze frame: Clear the fault and verify that the steering wheel is configured. Configure as stated above. Verify that both keys were on when the fault logged if possible.</li> <li>• If the fault is active only in port CCM or stored only in port CCM freeze frame: Verify that starboard key is on and recheck for active fault in port CCM. Verify configuration of the steering wheel is completed. If the fault is active in port CCM when only the port key is on, this is characteristic of the software and is only resolvable by turning the starboard key on.</li> </ul>

THE INFORMATION IN THIS DOCUMENT IS CONFIDENTIAL AND PROTECTED BY COPYRIGHT AND IS THE PROPERTY OF MERCURY MARINE.

This document is provided for the sole and exclusive use of the original recipient as prescribed by Mercury Marine and may not be distributed or copied, digitally or otherwise, without the prior written consent of Mercury Marine.