

TO: SERVICE MANAGER MECHANICS
PARTS MANAGER

No. 97-3

HP 500 BULLDOG INTERNAL CRANKSHAFT BALANCING

MODELS AFFECTED

All 1998 Model Year HP 500 Bulldog Engines.

SITUATION

All HP 500 Bulldog engines will be internally balanced starting with the 1998 model year. All HP 500 Bulldogs built previously to the 1998 model year were externally balanced. Three parts will change on the internal balanced engines.

1998 MODEL YEAR INTERNALLY BALANCE COMPONENTS

Flywheel P/N 230-9425-1

Damper P/N 49783-1

Crankshaft P/N 2408-849470

1997 MODEL YEAR AND ABOVE EXTERNALLY BALANCE COMPONENTS

Flywheel P/N 230-6540

Damper P/N 72605-1

Crankshaft P/N 2408-848108

IMPORTANT: Do not mix or match internal versus external parts listed above. Contact Hi-Performance with engine S/N if you need manufactures Bob weight.

SERVICE PARTS

The External Balanced Service Crankshaft (P/N 2408-848108) will supercede to the new internal balanced crankshaft (P/N 2408-849470). If changing crankshafts is required on a Pre -1998 500 (Bulldog) engine it will require a new flywheel and damper. (See above)

PARTIAL ENGINE

Partial engines will supersede to the new internal balanced long block after the remaining inventory of existing partial engines (P/N 816475A18) is depleted.

IDENTIFICATION

All HP 500 Bulldog complete and partial engines built with the new internal balance components will be identified by the letters "INT" stamped after the crankshaft serial number. This number is found on the front starboard side of the engine block at the cylinder head deck surface.

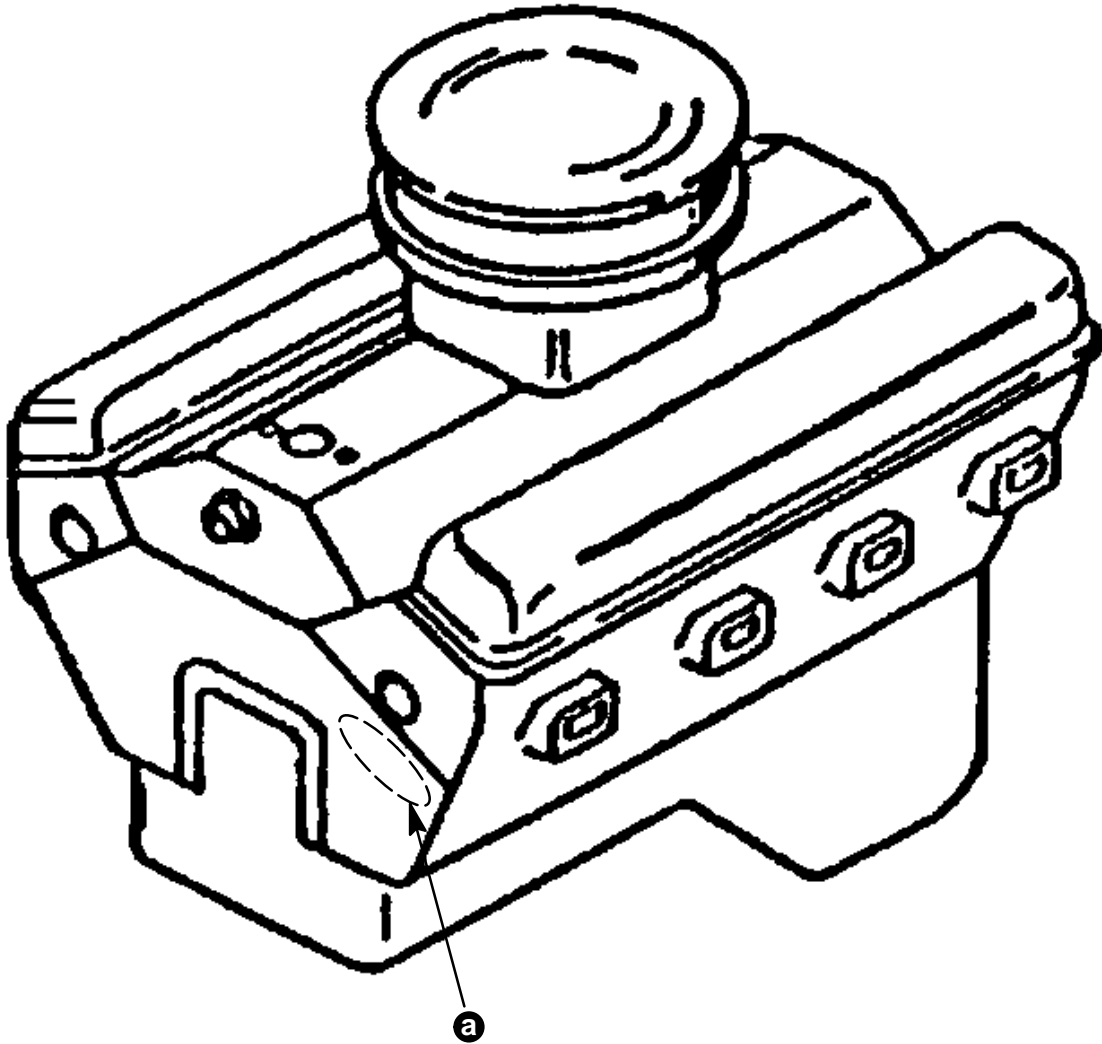

a - "INT" Identification stamp for internally balanced