

TO: SERVICE MANAGER MECHANICS
PARTS MANAGER

No. 98-3

Incorrect Marking on II-V SSM Service Tool # 91-816922-3

Shimming tool, part number 91-816922-3 which measures (2.198 in. Dia.) must have the stamped number of (1.33:1 and letter "Z").

If this tool is marked incorrectly, stamp the correct number and/or letter onto the tool and (xxxxx) out the incorrect number and/or letter.

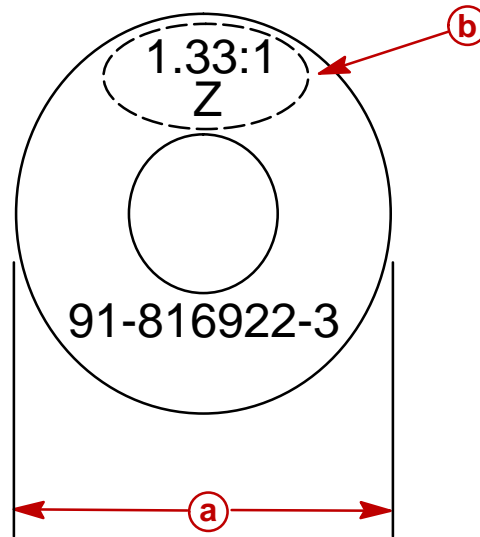

- a** - 2.198 in. Diameter Tool
- b** - Should Read